

MF72 NTC Thermistor

The MF72 power NTC thermistor is a kind of semiconductor ceramic element that mostly made from transition metal oxide material, and belongs to negative temperature thermistors. When you tune on an electrical equipment , the surge current can be restrained by a power NTC thermistor connected in series with the power circuit .

Because of the continuing action of current, temperature of power NTC thermistor raising, the resistance will rapidly drop to a small value, the consumed power can be ignored. So it can not affect normal operating current. Therefore, using power NTC thermistor is a most effectively amd most brief measure to restrain surge current, protecting electrical equipment from destruction.

Features

Small size , Strong power and strong capability of surge current protection.

Fast response to surge current.

Big material constant(B value), Small remain resistance.

Longevity of service, High reliability.

Integral series , Extensive operating range

Silicon Epoxy Coating, Copper Leads

RoHS Compliant

Application

Convension power supply , switch power , kinds of electric heater , energy-saving lamps , electronic ballast etc .

All kinds of power circuit protection of electronic equipments , filament protection of RT, display, bulb, lighting lamps .

Drawing & Demensions (Unit : mm)

Inside Kinked (Standard Shape)
Lead Style Code: 0

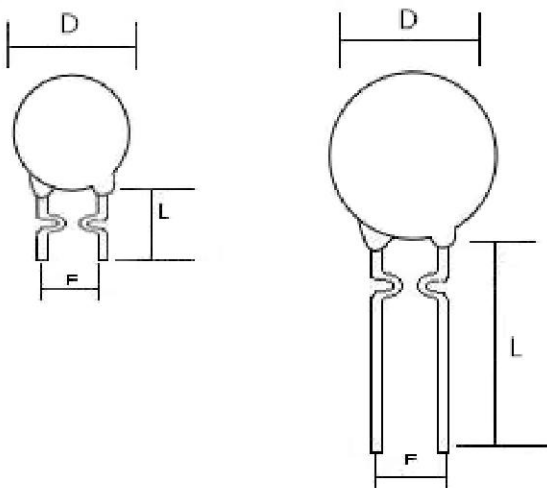

Straight leads (on request)
Lead Style Code: 1

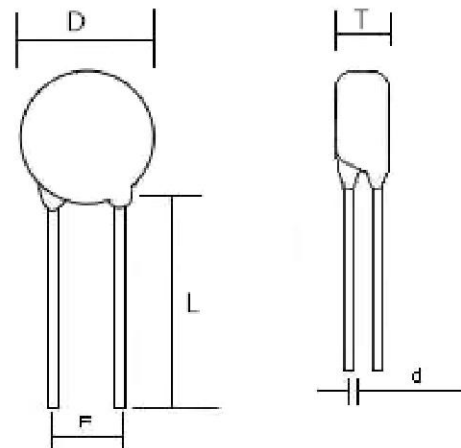

Drawing & Demensions (Unit : mm)

Y Kinked Leads (on request)
Lead Style Code: 8

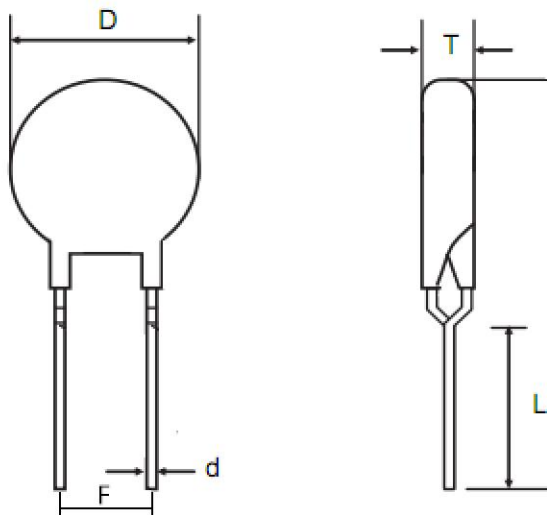

Dimensions: (mm)

style	core wire(Item No.15)	size (mm)			
		D max	T max	F±0.8	d±0.05
□D-5	CU (C)	7.0	4.5	5.0	0.6
	CP (F)				0.6
□D-7	CU (C)	9.0	5.0	5.0	0.6
	CP (F)				0.6
□D-9	CU (C)	11.0	6.0	5.0	0.8
	CP (F)				0.7
□D-11	CU (C)	13.0	6.5	7.5	0.8
	CP (F)				0.7
□D-13	CU (C)	15.5	7.0	7.5	0.8
	CP (F)				0.7
□D-15	CU (C)	17.5	7.0	7.5	0.8
	CP (F)				0.7
□D-20	CU (C)	22.5	7.0	10.0	1.0
	CP (F)				1.0

Basic Characteristics of NTC thermistor

□-5 series Basic Characteristics

style	Rated zero power resistance @25°C (Ω)	Maximum steady current @25°C (A)	Residual Resistor at Maximum Steady Current @25°C (Ω)	B value (K) ±10%	Thermal time constant (S)	Heat dissipation coefficient (mW/°C)	Operating temperature range (°C)
5D-5	5	1	0.353	2500	<20	>6	-40°C ~ 155°C
10D-5	10	0.7	0.771	2600	<20	>6	-40°C ~ 155°C
15D-5	15	0.6	1.53	2600	<20	>6	-40°C ~ 155°C
20D-5	20	0.5	1.253	2600	<20	>6	-40°C ~ 155°C
22D-5	22	0.6	2.06	2600	<20	>6	-40°C ~ 155°C
30D-5	30	0.4	2.227	2600	<20	>6	-40°C ~ 155°C
33D-5	33	0.4	1.324	2600	<20	>6	-40°C ~ 155°C
50D-5	50	0.4	2.653	2800	<18	>6	-40°C ~ 155°C
60D-5	60	0.3	1.878	2800	<18	>6	-40°C ~ 155°C

□-7 series Basic Characteristics

style	Rated zero power resistance @25°C (Ω)	Maximum steady current @25°C (A)	Residual Resistor at Maximum Steady Current @25°C (Ω)	B value (K) ±10%	Thermal time constant (S)	Heat dissipation coefficient (mW/°C)	Operating temperature range (°C)
5D-7	5	2	0.283	2600	<30	>10	-40°C ~ 175°C
8D-7	8	1	0.539	2600	<28	>9	-40°C ~ 175°C
10D-7	10	1	0.616	2800	<27	>9	-40°C ~ 175°C
12D-7	12	1	0.816	2800	<27	>9	-40°C ~ 175°C
16D-7	16	0.7	1.003	2800	<27	>9	-40°C ~ 175°C
20D-7	20	0.6	1.102	2800	<27	>9	-40°C ~ 175°C
22D-7	22	0.6	1.108	2800	<27	>9	-40°C ~ 175°C
30D-7	30	0.5	3.7059	2800	<28	>10	-40°C ~ 175°C
33D-7	33	0.2	1.485	2800	<28	>10	-40°C ~ 175°C
50D-7	50	0.5	1.653	2800	<28	>10	-40°C ~ 175°C

□-9 series Basic Characteristics

style	Rated zero power resistance @25°C (Ω)	Maximum steady current @25°C (A)	Residual Resistor at Maximum Steady Current @25°C (Ω)	Bvalue (K) ±10%	Thermal time constant (S)	Heat dissipation coefficient (mW/°C)	Operating temperature range (°C)
3D-9	3	4	0.120	2600	<35	>11	-40°C~175°C
4D-9	4	3	0.190	2600	<35	>11	-40°C~175°C
5D-9	5	3	0.210	2600	<34	>11	-40°C~175°C
6D-9	6	2	0.315	2600	<34	>11	-40°C~175°C
7D-9	7	2	0.3265	2800	<34	>11	-40°C~175°C
8D-9	8	2	0.400	2800	<32	>11	-40°C~175°C
10D-9	10	2	0.458	2800	<32	>11	-40°C~175°C
12D-9	12	1	0.652	2800	<32	>11	-40°C~175°C
16D-9	16	1	0.802	2800	<31	>11	-40°C~175°C
20D-9	20	1	0.864	3000	<30	>11	-40°C~175°C
22D-9	22	1	0.950	3000	<30	>11	-40°C~175°C
30D-9	30	1	1.022	3000	<30	>11	-40°C~175°C
33D-9	33	1	1.124	3000	<30	>11	-40°C~175°C
50D-9	50	1	1.252	3200	<30	>11	-40°C~175°C
60D-9	60	0.8	1.502	3200	<31	>11	-40°C~175°C
80D-9	80	0.8	2.010	3200	<30	>11	-40°C~175°C
120D-9	120	0.8	3.015	3200	<30	>11	-40°C~175°C
200D-9	200	0.5	5.007	3400	<32	>11	-40°C~175°C

□-11 series Basic Characteristics

style	Rated zero power resistance @25°C (Ω)	Maximum steady current @25°C (A)	Residual Resistor at Maximum Steady Current @25°C (Ω)	B value (K) ±10%	Thermal time constant (S)	Heat dissipation coefficient (mW/°C)	Operating temperature range (°C)
2.5D-11	2.5	5	0.095	2600	<43	>13	-40°C~175°C
3D-11	3	5	0.100	2600	<43	>13	-40°C~175°C
4D-11	4	4	0.150	2600	<44	>13	-40°C~175°C
5D-11	5	4	0.156	2800	<45	>13	-40°C~175°C
6D-11	6	3	0.240	2800	<45	>13	-40°C~175°C
7D-11	7	3	0.2824	2800	<45	>13	-40°C~175°C
8D-11	8	3	0.255	2800	<47	>14	-40°C~175°C
10D-11	10	3	0.275	2800	<47	>14	-40°C~175°C
12D-11	12	2	0.462	2800	<48	>14	-40°C~175°C
15D-11	15	2	0.468	2800	<50	>14	-40°C~175°C
16D-11	16	2	0.470	2800	<50	>14	-40°C~175°C
20D-11	20	2	0.512	3000	<52	>15	-40°C~175°C
22D-11	22	2	0.563	3000	<52	>15	-40°C~175°C
25D-11	25	2	0.623	3000	<52	>15	-40°C~175°C
30D-11	30	1.5	0.667	3000	<52	>15	-40°C~175°C
33D-11	33	1.5	0.734	3000	<52	>15	-40°C~175°C
47D-11	47	1.5	1.002	3200	<52	>15	-40°C~175°C
50D-11	50	1.5	1.021	3200	<52	>15	-40°C~175°C
60D-11	60	1.5	1.215	3200	<52	>15	-40°C~175°C
80D-11	80	1.2	1.656	3200	<52	>15	-40°C~175°C
120D-11	120	1.1	2.253	3000	<50	>15	-40°C~175°C

□-13 series Basic Characteristics

style	Rated zero power resistance @25°C (Ω)	Maximum steady current @25°C (A)	Residual Resistor at Maximum Steady Current @25°C (Ω)	B value (K) ±10%	Thermal time constant (S)	Heat dissipation coefficient (mW/°C)	Operating temperature range (°C)
1.3D-13	1.3	7	0.062	2600	<60	>13	-40°C ~ 200°C
1.5D-13	1.5	7	0.073	2600	<60	>13	-40°C ~ 200°C
2.5D-13	2.5	6	0.088	2600	<60	>13	-40°C ~ 200°C
3D-13	3	6	0.092	2600	<60	>14	-40°C ~ 200°C
4D-13	4	5	0.120	2800	<67	>15	-40°C ~ 200°C
4.7D-13	4.7	5	0.1469	2800	<67	>15	-40°C ~ 200°C
5D-13	5	5	0.125	2800	<68	>15	-40°C ~ 200°C
6D-13	6	4	0.170	2800	<65	>15	-40°C ~ 200°C
7D-13	7	4	0.188	3000	<65	>15	-40°C ~ 200°C
8D-13	8	4	0.194	3000	<60	>15	-40°C ~ 200°C
10D-13	10	4	0.206	3000	<65	>15	-40°C ~ 200°C
12D-13	12	3	0.316	3200	<65	>16	-40°C ~ 200°C
15D-13	15	3	0.335	3200	<60	>16	-40°C ~ 200°C
16D-13	16	3	0.338	3200	<60	>16	-40°C ~ 200°C
18D-13	18	3	0.356	3200	<60	>16	-40°C ~ 200°C
20D-13	20	3	0.372	3200	<65	>16	-40°C ~ 200°C
22D-13	22	3	0.625	3200	<65	>16	-40°C ~ 200°C
25D-13	25	2.5	0.422	3200	<65	>16	-40°C ~ 200°C
30D-13	30	2.5	0.517	3200	<65	>16	-40°C ~ 200°C
33D-13	33	2.5	0.592	3200	<65	>16	-40°C ~ 200°C
47D-13	47	2	0.810	3200	<65	>17	-40°C ~ 200°C
50D-13	50	2	1.161	3200	<65	>13	-40°C ~ 200°C
120D-13	120	1.2	2.124	3400	<65	>17	-40°C ~ 200°C

□-15 series Basic Characteristics

style	Rated zero power resistance @25°C (Ω)	Maximum steady current @25°C (A)	Residual Resistor at Maximum Steady Current @25°C (Ω)	B value (K) ±10%	Thermal time constant (S)	Heat dissipation coefficient (mW/°C)	Operating temperature range (°C)
1.3D-15	1.3	8	0.048	2600	<68	>18	-40°C ~ 200°C
1.5D-15	1.5	8	0.052	2600	<69	>18	-40°C ~ 200°C
2.5D-15	2.5	7	0.065	2800	<76	>18	-40°C ~ 200°C
3D-15	3	7	0.075	2800	<76	>18	-40°C ~ 200°C
4D-15	4	6	0.1985	2800	<76	>18	-40°C ~ 200°C
5D-15	5	6	0.112	3000	<76	>20	-40°C ~ 200°C
6D-15	6	5	0.155	3000	<80	>20	-40°C ~ 200°C
7D-15	7	5	0.173	3000	<80	>20	-40°C ~ 200°C
8D-15	8	5	0.178	3000	<80	>20	-40°C ~ 200°C
10D-15	10	5	0.180	3200	<75	>20	-40°C ~ 200°C
12D-15	12	4	0.250	3200	<75	>20	-40°C ~ 200°C
15D-15	15	4	0.268	3200	<85	>21	-40°C ~ 200°C
16D-15	16	4	0.276	3200	<70	>21	-40°C ~ 200°C
18D-15	18	4	0.3375	3200	<70	>21	-40°C ~ 200°C
20D-15	20	4	0.288	3200	<86	>21	-40°C ~ 200°C
22D-15	22	4	0.3812	3200	<86	>21	-40°C ~ 200°C
25D-15	25	3.5	0.358	3200	<86	>21	-40°C ~ 200°C
30D-15	30	3.5	0.438	3200	<75	>21	-40°C ~ 200°C
33D-15	33	3	0.571	3200	<86	>21	-40°C ~ 200°C
40D-15	40	3	0.587	3200	<86	>21	-40°C ~ 200°C
47D-15	47	3	0.680	3200	<86	>21	-40°C ~ 200°C
50D-15	50	3	0.734	3200	<86	>21	-40°C ~ 200°C
120D-15	120	1.8	1.652	3400	<87	>22	-40°C ~ 200°C

□-20 series Basic Characteristics

style	Rated zero power resistance @25°C (Ω)	Maximum steady current @25°C (A)	Residual Resistor at Maximum Steady Current @25°C (Ω)	B value (K) ±10%	Thermal time constant (S)	Heat dissipation coefficient (mW/°C)	Operating temperature range (°C)
0.7D-20	0.7	11	0.018	2400	<89	>24	-40°C ~ 200°C
1.3D-20	1.3	9	0.037	2600	<88	>24	-40°C ~ 200°C
2.2D-20	2.2	8	0.1292	2800	<88	>24	-40°C ~ 200°C
2.5D-20	2.5	8	0.052	2800	<88	>24	-40°C ~ 200°C
3D-20	3	8	0.055	2800	<88	>24	-40°C ~ 200°C
5D-20	5	7	0.087	3000	<87	>24	-40°C ~ 200°C
6D-20	6	6	0.113	3000	<103	>25	-40°C ~ 200°C
8D-20	8	6	0.142	3000	<105	>25	-40°C ~ 200°C
10D-20	10	6	0.162	3200	<102	>25	-40°C ~ 200°C
12D-20	12	5	0.195	3200	<100	>25	-40°C ~ 200°C
16D-20	16	5	0.212	3200	<100	>25	-40°C ~ 200°C

MF72 NTC Thermistor**Marking on body**

	item		
	①	UF	Logo
	②	16	Zero Power Resistance at 25°C
	③	D	Round shape
	④	9	Diameter (mm)
	⑤	M	Zero Power Resistance Tolerance

How to order

<u>MF72</u>	<u>09</u>	<u>100</u>	<u>M</u>	<u>SC</u>	<u>0050</u>	<u>A</u>	<u>00</u>
Type	09: 9mm dia.	Zero Power Resistance	Tolerance	Epoxy Coat Material Lead type	Package Code	Package Code	Suffix Indicate Special Requirement
MF72	10: 10.0mm 07: 7.0mm	0R5 = 0.5 Ω 080 = 8 Ω 100 = 10 Ω	M: +/-20% L: +/-15% M: +/-20% N: +/-25%	SC: Silicone Coat (Green) Copper wire PF: Phenolic Coat (Black) CP Wire	Inside kinked 5mm pitch First code represent lead style code. The following 3 digits represent pitch size 100: pitch size 10mm 050: pitch size 5mm	B: Bulk A: Ammo Taped R: Tape & Reel	00: Indicating Standard